

## Series: V85000 (HH & HV models)

### Submersible Dewatering Pumps 6" NPT Female Discharge



**Series:  
V85000**

**50.0hp, 3Ph  
HH & HV models**

V-Power pumps are compact, lightweight powerful Portable Electric Submersible Pumps. They are whisper quiet and will perform in any position. V-Power pumps can be staged in series for higher head applications.

The V-Power in-line design assures maximum heat transferred to the pumped liquid. V-Power pumps can operate in up to 140°F (60°C) temperature water. V-Power design provides the coolest operating motor for maximum life.

Consult the factory prior to pumping fluids other than water for professional instructions.

#### **Vacuum Pressure Impregnation "VPI" Sealed Insulation System**

VPI motor enhancement system was developed to greatly extend the winding life expectancy of an electric motor. The motor stator is loaded into a pressure vessel and immersed in the specialty selected varnish.

All gas pockets located within the stator are evacuated under vacuum. The varnish is drawn into the stator core, completely occupying all voids in the winding. Following a series of processes, ending in a controlled bake, the winding is 100% impregnated and sealed.

<b>DISCHARGE CASE</b>	Aluminum, Hard Anodized
<b>DIFFUSER</b>	Aluminum, Hard Anodized
<b>SUCTION CASE</b>	Aluminum, Hard Anodized, with wear resistant polyurethane liner
<b>FRAME &amp; OUTER CASE</b>	Aluminum, Hard Anodized
<b>WEAR PLATE</b>	Polyurethane
<b>PUMP SHAFT</b>	Stainless Steel
<b>IMPELLER</b>	Hardened 17-4 Stainless Steel
<b>HARDWARE</b>	Stainless Steel
<b>O-RINGS</b>	Buna-N
<b>SEAL</b>	Tandem mechanical, Oil lubricated
<b>INBOARD</b>	Material: Rotating Face - Carbon Stationary Face - Ceramic Elastomer - Buna-N Hardware - 300 Series Stainless
<b>OUTBOARD</b>	Material: Rotating Face - Silicon Carbide Stationary Face - Silicon Carbide Elastomer - Viton® Hardware - 300 Series Stainless
<b>STRAINER</b>	Stainless Steel, 1/4" Holes
<b>UPPER BEARING</b>	Single Row, Shielded, Ball Lubrication: Prelubricated high-temperature grease Load: Radial
<b>LOWER BEARING</b>	Double Row, Shielded, Ball Lubrication: Prelubricated high-temperature grease Load: Radial & Thrust
<b>CORD ENTRY</b>	50Ft. with Strain Relief and Pressure Grommet for Sealing
<b>MOTOR</b>	Insulation: Class F
<b>CONTROL</b>	NEMA 3R Rainproof

MODEL	POWER CORD WEIGHT	CONTROL BOX WEIGHT	PUMP ONLY WEIGHT	SHIPPING WEIGHT
50 hp	52.8 lbs	8.8 lbs	350 lbs	445 lbs

VPI is greatly superior to the "dip and bake" method which may provide only 50% to 70% of effective insulation leaving voids and air pockets. VPI provides 100% solid mass structure which provides the greatest mechanical strength and a cooler running motor due to superior heat dissipation.

# Series: V85000 (HH & HV models)

## Submersible Dewatering Pumps 6" NPT Female Discharge

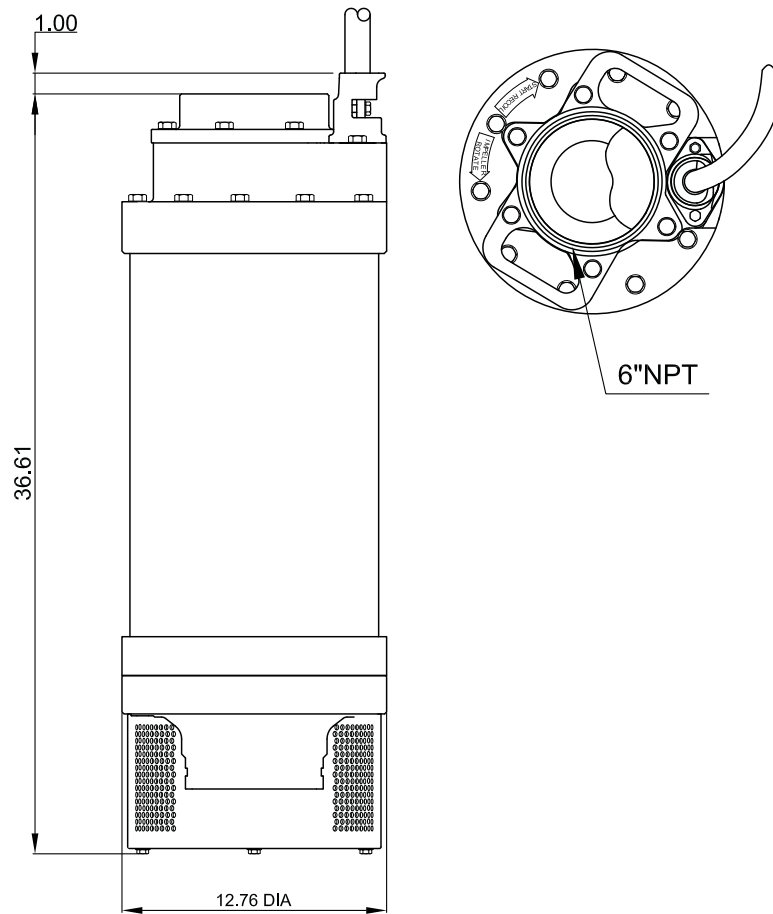

MODEL #	HP	VOLT/PH	Hz	RPM	NEMA START CODE	FULL LOAD AMPS	LOCKED ROTOR AMPS	CORD SIZE	CORD TYPE	MAX CORD LENGTH (FT)
<b>HH SERIES W/ NEMA 3R RAINPROOF CONTROL</b>										
<b>V85034HH</b>	50	460/3	60	3450	G	56.0	360.0	4/4	SOW	790
<b>HV SERIES W/ NEMA 3R RAINPROOF CONTROL</b>										
<b>V85034HV</b>	50	460/3	60	3450	G	56.0	360.0	4/4	SOW	790

### IMPORTANT APPLICATION INFORMATION !

- 1) FOR THOSE APPLICATIONS SPECIFIED AS CLASS I DIVISION II HAZARDOUS LOCATIONS THIS PUMP AND CONTROL SUPPLIED ARE NOT APPROPRIATE FOR HAZARDOUS LOCATIONS.
- 2) INSTALLATIONS SUCH AS DECORATIVE WATER FEATURES MUST BE INSTALLED IN ACCORDANCE WITH THE NATIONAL ELECTRIC CODE ANSI/NFPA 70. THIS PUMP IS NOT INTENDED FOR USE IN RECREATIONAL WATER PARKS, SWIMMING POOLS, OR INSTALLATIONS IN WHICH HUMANS ARE IN CONTACT WITH THE PUMPED FLUID.

# Series: V85000 (HH & HV models)

## Submersible Dewatering Pumps 6" NPT Female Discharge

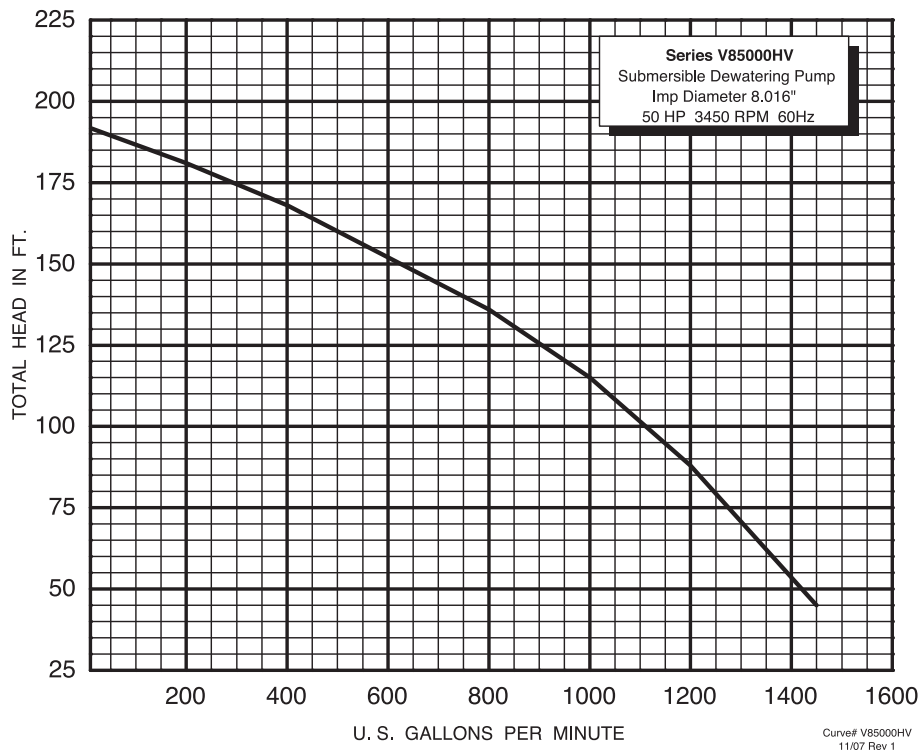
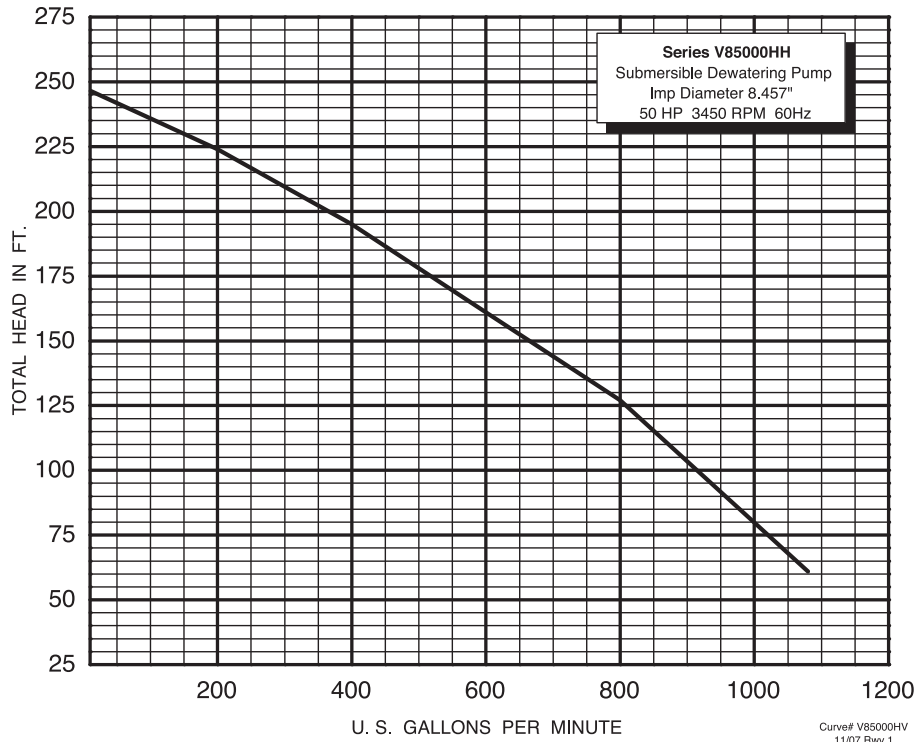

# Series: V85000 (HH & HV models)

Submersible Dewatering Pumps  
6" NPT Female Discharge

## 50 hp (3 Phase) Control Box

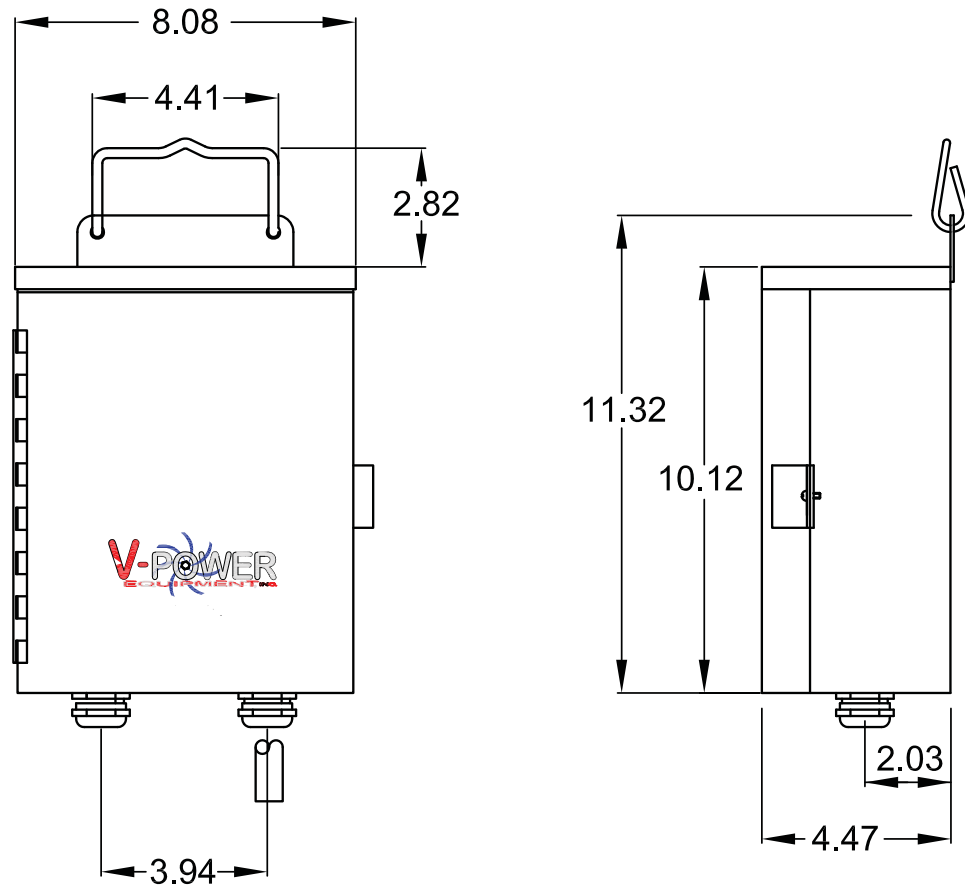

### NEMA 3R RAINPROOF CONTROL

Pump P/N:	Control P/N
V85034HH	V850834
V85034HV	V850834

