

T-GRIP™

PORTABLE 4" TUBE DELINEATOR WITH DIAMOND SERIES BASE

TD5100T MODEL

THE "EASY TO GRAB" T-GRIP™ SETS THE STANDARD FOR PORTABLE DELINEATORS



Reinforced bolt hole for warning lights.

Support rings around reflective bands for added tape protection.

Meets EPA guidelines for Recycled Content.

Made from 95% Post-Consumer Recycled high impact polyethylene utilizing polymer protection UV stabilizer.

The TD5100T T-GRIP™ Delineator is available in Fluorescent Orange. Three D Traffic Works can manufacture this product to your desired color upon request.

GENERAL INFORMATION:

General information is listed on the reverse side. The measurements provided are intended only as a source of information. They are given without guarantee and are not classified as a warranty. A specification will be sent to you upon request.





TD5100T MODEL T-GRIP™ DELINEATOR SPECIFICATIONS

I Dimensions:
Height: 48 Inches.
Width: 4 Inches.

I All Sheeting Complies
With ASTM 4956.01
Requirements.

I TD5100T T-GRIP™ Portable Delineator is a two-piece design consisting of a HDPE Tube and TD8000 Diamond Series 100% Post-Consumer Recycled Rubber Base.

I Tube Material: Dioxin-Free High Density Polyethylene with 95% Post-Consumer Recycled Content.

I Available with 100% Post-Consumer Recycled Diamond Series Rubber Bases in 8 lb, 10 lb, 11 lb, 12 lb, 15 lb, and 18 lb weights. See TD8000 Diamond Base literature for benefits.

I Square Rubber Bases available in 11 lb weight. This base is 16 X 16 inches square, providing excellent stability and support.

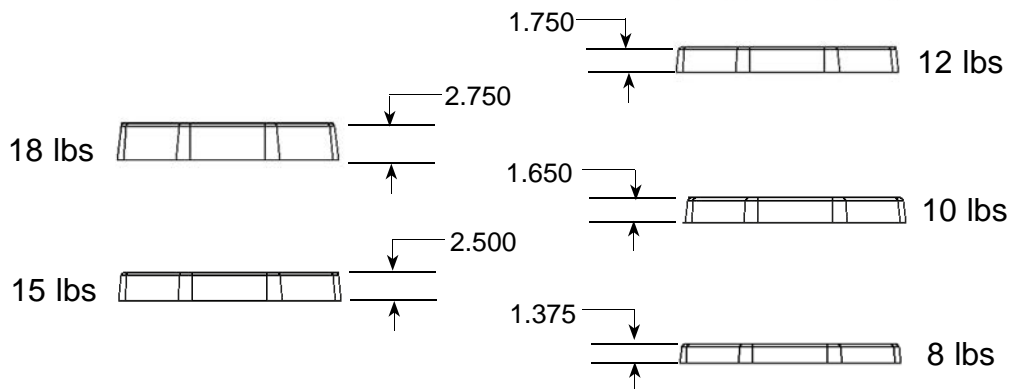
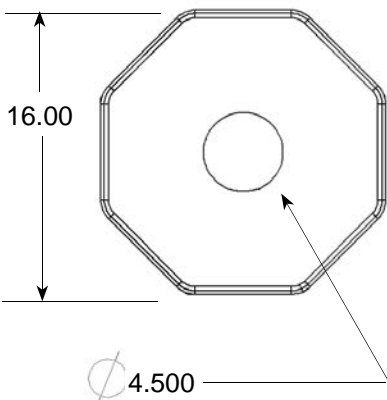
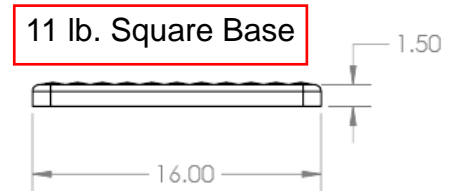
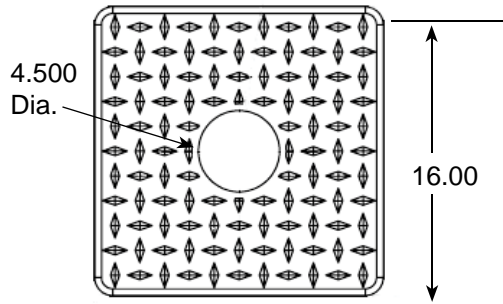
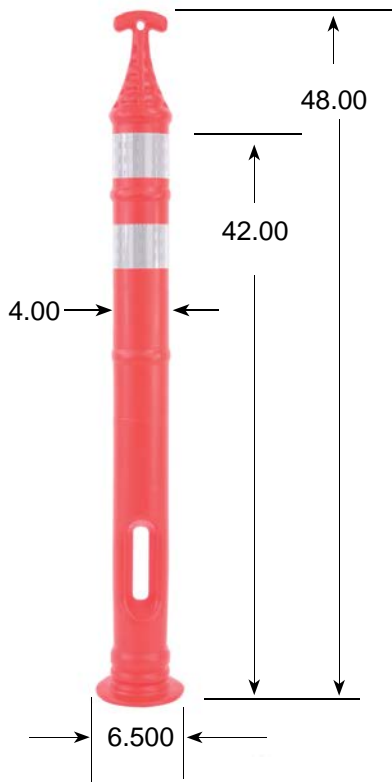

I TD8000 Series Diamond Base Material is 100% Post-Consumer Recycled Rubber.