

Power Blower

The DCD Power Blower is unique, a portable unit with the maximum pressure available in this class of line blowers: up to 30% higher. While there are several other similar products on the market, the DCD unit offers an excellent list of special features, including:

- Acceptable for outdoor use (not in rain).
- Heavy duty industrial three-stage motor with sealed bearings and delivering up to 95 cfm and 5 psi.
- A heavy-duty 2" hose made of crush resistant polyethylene, 15' long, which will stand up in temperatures from -40°F to +140°F.
- The blowers operate at 110/120VAC and require 15 amp source. A 220V/110V voltage convertor and a plug adapter are also available.



Although other manufacturers have a higher cfm rating, that will only increase the speed of the dart. The higher pressure rating is key because this will allow a dart carrying pull tape or twine to travel further with higher loads, even though it might take a few seconds longer (see below for a full explanation).

DCD also offers a full line of blowing accessories detailed on the following pages, available as kits or individually to build your own toolbox. DCD Line Blowing products feature a range of innovations to suit your application and go farther.

Part No.	Description	Weight
58400-000	Power Blower 110V	20.8 lb
58400-110	Power Blower with 15' Hose (2" dia.) and Seal Offs for 1/2" to 6" duct	26.8 lb
58400-200	Power Blower (58400-000) with Voltage Converter (58400-201)	74.7 lb
58400-201	Voltage Converter to convert 220V power to 110V	58.0 lb
58400-220	Power Blower (58400-000) with Voltage Converter (58400-201), 15' Hose (2" dia.), and Seal Offs for 1/2" to 6" Duct	94.8 lb
58410-025	25' Optional Hose (2" dia.)	10.5 lb

Understanding Blower Performance

The output of a blower is usually specified in terms of its flow rate (cfm) and its pressure (psi). The flow rate determines how fast the blower can move a projectile, and the pressure determines how much load the projectile can pull and how far it can pull it.

When a blower is running with an unrestricted outlet, it will produce its maximum specified flow rate because there is no resistance against it.

If the blower is attached to a length of empty conduit, the blower has to move all the air in the conduit to push any through. Friction against the conduit wall will resist that movement. As the blower works against this backpressure, its flow rate drops.

Therefore a blower can never produce its maximum advertised flow rate in a practical application due to air friction in the duct.

As the length of conduit increases, friction increases, backpressure increases, and flow rate decreases. At some point, the backpressure will increase to a point at which it equals the maximum pressure that the blower can generate, and the flow rate will be zero.

When a projectile is inserted, it blocks the conduit. As more air is pushed in behind the projectile, the backpressure rises until it exceeds the projectile's drag and it begins to move along the conduit. Therefore the drag creates the backpressure, which, in turn, determines the blower flow rate and ultimately the speed of the projectile.

As the projectile moves down the conduit, the drag force increases because of the weight and friction of the line being pulled is increasing. At some distance, the increasing backpressure equals the maximum pressure that the blower can develop, and the projectile will stall.

Because only blowing pressure can overcome backpressure, a blower with higher blowing pressure capability will ultimately go farther. The DCD Power Blower is designed around a high-pressure motor to go farther. More pressure, more distance.

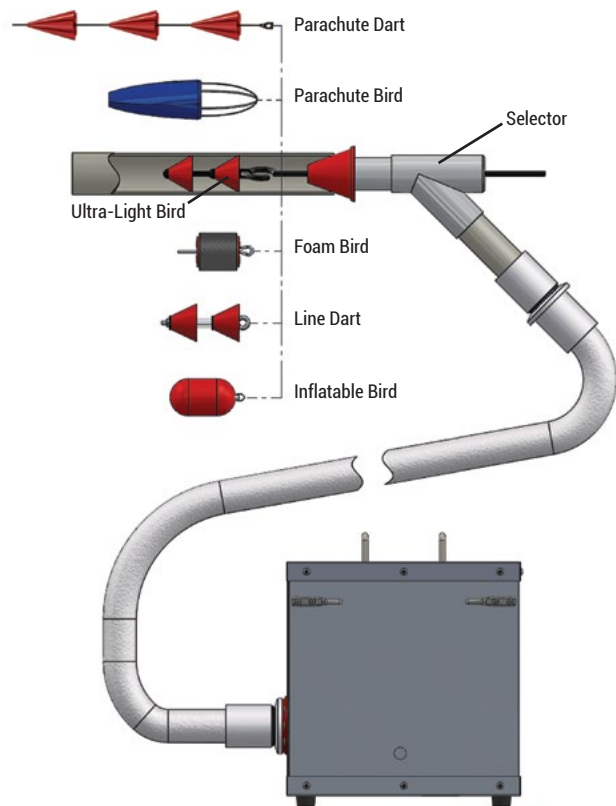

Hose Assembly

The Hose Assembly is made from crush-proof 2" hose and is 15' or 25' in length. At the end where the Seal Off Body attaches, there is a swivel connector allowing the body to be turned in any direction.



Part No.	Description	Weight
58410-015	Hose Assembly - 2" dia. x 15' L	7.10 lb
58410-025	Hose Assembly - 2" dia. x 25' L	10.50 lb
58410-100	Carrying Bag for Hose	1.93 lb

Seal Offs

The three Seal Off sizes are designed to cover all duct sizes from 1/2" to 6". Each of the units will attach directly onto the Seal Off Body which, in turn, attaches onto the Hose Assembly.



Part No.	Description	Weight
58420-010*	Seal Off Adapter - 1/2" to 1-1/2"	0.36 lb
58420-020*	Seal Off Adapter - 1-1/2" to 3"	0.72 lb
58420-030*	Seal Off Adapter - 2-1/2" to 6"	2.01 lb
58420-040*	Seal Off Body	1.46 lb
58420-000	Kit - Includes above parts marked *	4.55 lb

Line Darts

DCD Line Darts are unique for several reasons. The edges of the cones are tapered to allow better flexing when required to go around bends, etc. The thin edges will also flare out to give better sealing and faster blowing once under pressure. Spare cones are available and replacement is simple.



Part No.	Nominal Duct Size	Length	Color Code	Weight	Spare Cones
58300-100	1"	2-5/8"	Red	0.04 lb	58350-100
58300-125	1-1/4"	3-1/16"	Yellow	0.06 lb	58350-125
58300-150	1-1/2"	3-1/2"	Black	0.07 lb	58350-150
58300-200*	2"	5"	Green	0.17 lb	58350-200
58300-250*	2-1/2"	5-1/4"	Red	0.18 lb	58350-250
58300-300*	3"	5-5/8"	Yellow	0.27 lb	58350-300
58300-400*	4"	7-1/8"	Blue	0.37 lb	58350-400
58300-401*	4" PVC	7"	Red	0.37 lb	58350-401
58300-500	5"	8-3/8"	Orange	0.75 lb	58350-500
58300-600*	6"	9-1/4"	Black	0.94 lb	58350-600
58300-800	8"	10-31/32"	Black	1.76 lb	58350-800
58300-1100	11"	14-21/32"	Black	4.04 lb	58350-1100
58300-KT1	Kit - Includes above parts marked *	-	-	6.00 lb	-

Note: Other PVC options available upon request.

Parachute Darts

Also known in the industry as a Triple Shuttle, this device is intended to be blown through a duct with compressed air and pull tape or rope which is attached to the rear eye of the dart. Similar to the line darts and ultralight birds, the fabric is flexible, allowing it to flex when going around bends. It consists of three synthetic fabric parachutes attached to our tried and tested flexible fiberglass rod. The use of three parachutes provides the best reliability in catching air and pulling the tape down the conduit.



Part No.	Nominal Duct Size	Length	Parachute Size	Weight
58340-200	1" to 2"	19-1/2"	1-1/8"	0.09 lb
58340-400	2-1/2" to 4"	29-1/2"	2-1/4"	0.13 lb
58340-600	4-1/4" to 6"	37-1/2"	4-1/4"	0.15 lb
58340-800	6-1/4" to 8"	37-1/2"	5-1/4"	0.17 lb
58340-1200	10-1/4" to 12"	37-1/2"	6-5/8"	0.20 lb

Foam Birds

DCD Foam Birds are one of the more common ways to carry pull tapes through empty ducting. The product can also be used to spread lubricant through the duct before pulling cable. Sizes are standard and will fit duct sizes 2" through 6".



Part No.	Nominal Duct Size	Weight
58230-125	1-1/4"	0.06 lb
58230-200*	2"	0.06 lb
58230-250*	2-1/2"	0.06 lb
58230-300*	3"	0.09 lb
58230-350	3-1/2"	0.12 lb
58230-400*	4"	0.14 lb
58230-500	5"	0.27 lb
58230-600*	6"	0.39 lb
58230-KT1	Kit - Includes above parts marked *	0.74 lb

Ultra Light Birds

Unique to DCD, these birds are made out of polyurethane and, as the name implies, are about half the weight of the regular Line Darts. The cones are very tough yet extremely thin – so thin, in fact, that they can be easily inverted in the event that the dart gets stuck and it is necessary to pull them back out.



Part No.	Nominal Duct Size	Rear Eye Diameter	Weight
58320-200*	2"	1/4"	0.04 lb
58320-250*	2-1/2"	1/4"	0.04 lb
58320-300*	3"	1/4"	0.08 lb
58320-350	3-1/2"	1/4"	0.11 lb
58320-400*	4"	1/4"	0.14 lb
58320-500	5"	1/4"	0.28 lb
58320-600*	6"	1/4"	0.38 lb
58320-KT1	Kit - Includes above parts marked *		1.02 lb

Inflatable Birds

Although many companies offer this Inflatable style of bird, DCD's version is made of coated nylon and stitched for greater strength. The purpose of the Inflatable is to be able to blow through ducting already containing cable.



Part No.	Nominal Duct Size	Weight
58330-075	3/4" to 1-1/4"	0.01 lb
58330-150	1-1/2" to 2-1/2"	0.03 lb
58330-300	3" to 4"	0.06 lb
58330-500	5" to 6"	0.07 lb
58330-KT1	Kit - Includes all above parts	0.62 lb

Parachute Birds

With a large open mouth, these Parachutes are able to grab all the air blown into the duct and will travel faster and farther than any other model. They are made out of coated nylon and can be used in occupied duct.



Part No.	Nominal Duct Size	Color Code	Weight
58335-100	1" to 2"	Red	0.04 lb
58335-200	2" to 3"	Blue	0.15 lb
58335-300	3" to 4"	Brown	0.12 lb
58335-400	4" to 6"	Green	0.15 lb
58335-KT1	Kit - Includes all above parts		0.89 lb

Control Valve

The Control Valve is an integral part of the DCD blowing system. A ball valve allows control of air flow and quick disconnect fittings are attached at both ends. Three Rope Guides are included with each Control Valve purchased.



Part No.	Description	Weight
58000-000	Control Valve with Rope Guides	2.47 lb
58000-188	Rope Guide - 3/16"	0.10 lb
58000-250	Rope Guide - 1/4"	0.07 lb
58000-375	Rope Guide - 3/8"	0.04 lb

Control Valve Adapter

The Control Valve Adapter allows connection of the Control Valve to the Seal Off Adapters (58420 series).



Part No.	Description	Weight
58000-100	Control Valve Adapter	4.0 lb



Innerduct Seals

DCD offers two types of seals. The Innerduct Seal is a screw-in type that requires one product for each duct size. The second type is a Universal Seal which is a tapered product suitable for all duct sizes from 1" to 2". This is for use on short distance blowing where simply holding the seal against the end of the duct will do the job and save time.

The Kit comprises all four Innerduct Seals plus the Universal Seal. A Control Valve and Rope Guides are also included.



Part No.	Description	Nominal Duct Size	Weight
58100-000	Universal Seal	1" to 2"	1.50 lb
58100-100	Innerduct Seal	1"	1.40 lb
58100-125	Innerduct Seal	1-1/4"	2.20 lb
58100-150	Innerduct Seal	1-1/2"	3.02 lb
58100-200	Innerduct Seal	2"	3.96 lb
58150-000	Universal Kit with Control Valve, 4 Innerduct Seals, and 1 Universal Seal	1" to 2"	18.0 lb

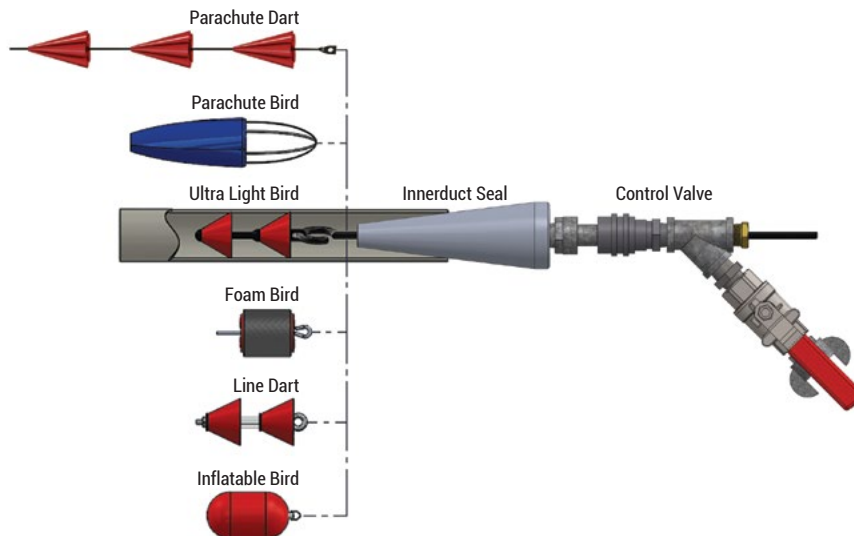

Duct Seals

Duct Seals are unique for several reasons. The expandable seals are colour coded for easy recognition. They are made from a specially formulated polyurethane designed to give maximum sealing and expansion properties.

While a single seal is difficult to align properly, a double seal is expensive.

The DCD unit has a single seal, but supports it with an alignment washer. Economical but effective. All seal sizes fit over the same Handle Assembly and changing the size of seal used is a breeze. Just unscrew two nuts, slide off one Seal Kit and slide on the next one.

The end of the unit is fitted with a quick release coupling. Each Seal Kit comes complete with the polyurethane seal, two compression washers and one stabilizing washer. Just order the size of seal you need plus one Handle Assembly. Next time, just order the new size of seal you need.

Note: All seals have been tested to at least 15% higher than stated values. The actual pressure attained may depend on the condition of both the duct and the Seal Kit. Care should be taken at all times when working with pressurized systems.

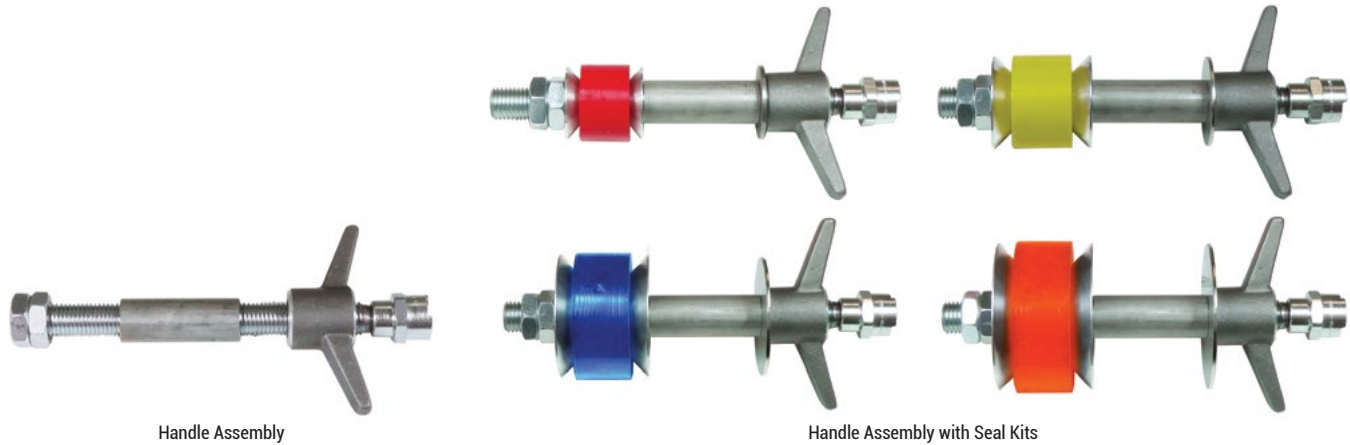

Part No.	Description	Nominal Duct Size	Minimum Duct Inside Diameter	Maximum Duct Inside Diameter	Color Code	Maximum Tested Pressure	Weight
58200-000	Handle Assembly	-	-	-	-	-	3.00 lb
58200-200	Duct Seal Kit	2"	1-13/16"	2-5/16"	Green	40 psi	0.23 lb
58200-250	Duct Seal Kit	2-1/2"	2-3/16"	2-3/4"	Red	35 psi	0.45 lb
58200-300	Duct Seal Kit	3"	2-13/16"	3-3/8"	Yellow	30 psi	0.93 lb
58200-350	Duct Seal Kit	3-1/2"	3-1/4"	3-13/16"	White	25 psi	1.23 lb
58200-400	Duct Seal Kit	4"	3-5/8"	4-1/4"	Blue	20 psi	1.59 lb
58200-500	Duct Seal Kit	5"	4-1/2"	5-1/8"	Orange	15 psi	2.67 lb
58200-600	Duct Seal Kit	6"	5-3/8"	6-1/16"	Black	10 psi	3.81 lb
58200-800	Duct Seal Kit	8"	7-5/8"	8"	Red	10 psi	9.40 lb

Note: Handle Assembly and one Duct Seal Kit are required to properly use this product.

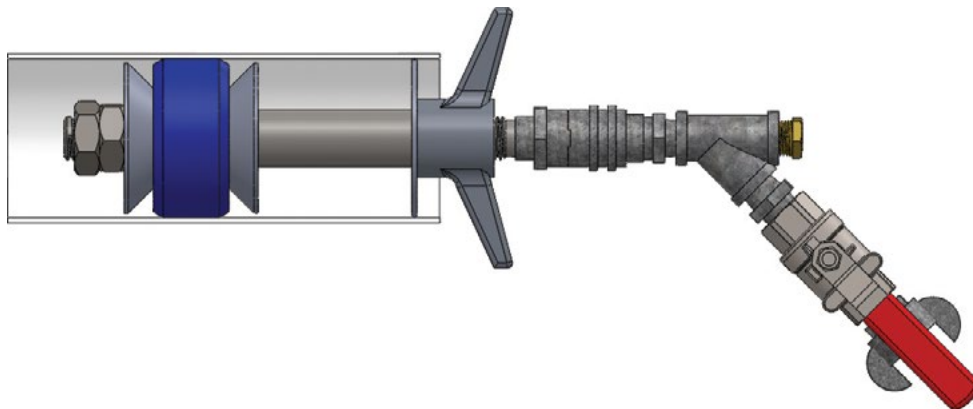

Spool Frame with Support Cones

The DCD Spool Frame is engineered for years of trouble free usage. While DCD offers this product for carrying our Pull Tapes, it can also be used for carrying data and communication cable drums. It has an easy fold up frame that is convenient for carrying or storage and does not require removing the spool or the 1/2" dia. spool support bar.

After a customer request, we designed the support cones, which prevents the spool from rocking during use and provides increased stability for the unit.



Part No.	Description	3:1 Safe Working Load	Capacity	Weight
58540-010	Spool Frame with Bar	100 lb	16-1/2" W x 20" dia.	7.85 lb
58540-020	Spool Frame with Bar and Cones	100 lb	16-1/2" W x 20" dia.	8.25 lb
58540-015	Replacement Cones	-	-	0.40 lb

Tapes and Twine

DCD partnered with Arncos in handling a wide range of high performance Bull-Line™ Pull Tape products to expedite cable installation. Choose from woven polyester tape products which are available in a variety of strength and lengths. A single pull tape eliminates the additional labor required for string, rope or winch line combinations.

All Bull-Line™ tape is manufactured with the Stiff-Tape™ lubricated coating, resulting in the highest performance pull table available in the industry.

Whatever the choice, Bull-Line™ Pull Tapes have continually provided a superior alternative to plastic pull ropes in cable installations through all types of conduit. Bull-Line™ Pull Tapes meet or exceed all pull line requirements of Bellcore GR-356-CORE.



Polyester Bull-Line™ is the most economical pull tape, very strong and durable and the elongation at yield is about 12% to 15%. Detectable tape have a 22 gauge solid copper wire woven into the tape.

Note: Can be pulled with our Fiber Cable Puller (42700 series).

Part No.	Description	Tensile Strength	Weight
58500-530	Pull Tape Pre-Lubricated - 1/2" x 3,000'	1,250 lb	24.5 lb
58500-630	Pull Tape Pre-Lubricated - 5/8" x 3,000'	1,800 lb	32.5 lb
58500-665	Pull Tape Pre-Lubricated - 5/8" x 6,560' (2,000 m)	1,800 lb	78.0 lb
58500-730	Pull Tape Pre-Lubricated - 7/8" x 3,000'	2,500 lb	48.5 lb
58500-765*	Pull Tape Pre-Lubricated - 7/8" x 6,560' (2,000 m)	2,500 lb	109.0 lb
58510-550	Detectable Pull Tape - 1/2" x 5,000'	1,250 lb	54.5 lb
58510-650	Detectable Pull Tape - 5/8" x 5,000'	1,800 lb	70.5 lb
58520-001	Measuring Tape - 3/16" x 3,000'	160 lb	3.7 lb
58530-001	Blowing Twine with Pail and Lid - 7,000'	180 lb	12.0 lb
58530-002	Blowing Twine with Pail and Lid - 3,000'	400 lb	12.5 lb

* Wood reel standard.
Note: Other sizes available upon request. Wood reels available in pallet quantities only.