

Submersible Dewatering Pumps

| | |
|--|---|
| DISCHARGE CASE | 356T6 Aluminum, Hard Anodized |
| DIFFUSER | 356T6 Aluminum, Hard Anodized |
| SUCTION CASE | 356T6 Aluminum, Hard Anodized, with wear resistant polyurethane liner |
| FRAME & OUTER CASE | 6063T6 Aluminum, Hard Anodized |
| WEAR PLATE | Polyurethane |
| PUMP SHAFT | Stainless Steel |
| IMPELLER | Hardened 17-4 Stainless Steel |
| HARDWARE | Stainless Steel |
| O-RINGS | Buna-N |
| SEAL <i>Design</i> | Tandem mechanical, Oil lubricated |
| INBOARD <i>Material</i> | Rotating Face - Carbon Stationary Face - Ceramic Elastomer - Buna-N Hardware - 300 Series Stainless |
| OUTBOARD <i>Material</i> | Rotating Face - Silicon Carbide Stationary Face - Silicon Carbide Elastomer - Viton® Hardware - 300 Series Stainless |
| STRAINER | 300 series stainless steel, .25" (6.35mm) Holes |
| UPPER BEARING: | |
| <i>Design</i> | Single Row, Shielded, Ball |
| <i>Lubrication</i> | Prelubricated high-temperature grease |
| <i>Load</i> | Radial |
| LOWER BEARING: | |
| <i>Design</i> | Single Row, Shielded, Ball |
| <i>Lubrication</i> | Prelubricated high-temperature grease |
| <i>Load</i> | Radial & Thrust |
| CORD ENTRY | 50Ft. (15m) with Strain Relief and Pressure Grommet for Sealing |
| MOTOR: <i>Design</i> | NEMA Design B - Three Phase, Squirrel Cage Induction |
| <i>Insulation</i> | Class F |
| CONTROL: <i>Three Phase</i> | Rainproof NEMA 3R. Provides with Circuit Breaker for overload and short circuit protection |
| OPTIONAL EQUIPMENT | Watertight, NEMA 4 Control. Discharge Adapters kits, Carrying Handle, Sludge Strainer, Viton® Seals, and Lift Cord. See accessory section for additional information. |

50HZ DATA AVAILABLE UPON REQUEST

WARRANTY INVALID IF CORRECT PROSSER CONTROL IS NOT USED AT ALL TIMES.

WEIGHT
Pump Only - 73 lbs./ 33 kg.
Control - 12 lbs./ 5.4 kg.
Cord - .27 lbs/Ft / .40kg/m

SHIPPING WT./STD. UNIT
Pump, Cord & Control
Domestic - 102 lbs. / 46 kg
Export - 139 lbs. / 4.5 Cu. Ft.

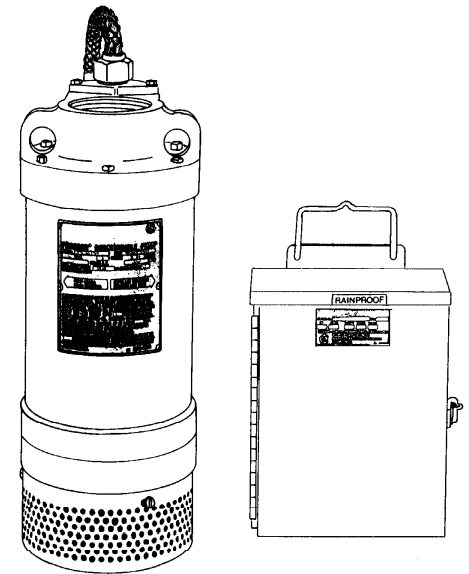

Series: 9-55000, 5.0HP, 3Ph
2 Stage



CSA 108 - File No. LR16567
UL 778

DESCRIPTION:

Prosser's small but powerful Portable Electric Submersible Pumps are compact, lightweight units. They are quiet and will operate in any position. No priming, suction hose or foot valves are required. Prosser pumps can be easily staged for higher head applications. The patented outboard shaft seal on this pump is a specially designed silicon carbide abrasive resistant type "S" shaft seal, which offers greater service life. A special abrasion resistant suction case lining and wear plate is a standard feature that protects the pump against wear from abrasive laden water.

The unique in-line design assures a cool running motor with heat transferred to the pumped liquid. Prosser pumps can operate in up to 140°F (60°C) temperature water and within a range of 5 to 9PH.

Before pumping fluids other than water consult the factory, giving fluid, fluid temperature, specific gravity, viscosity, capacity in USGPM and total head and/or pressure requirements, including friction loss through discharge line, fittings, valves, etc.

Submersible Dewatering Pumps

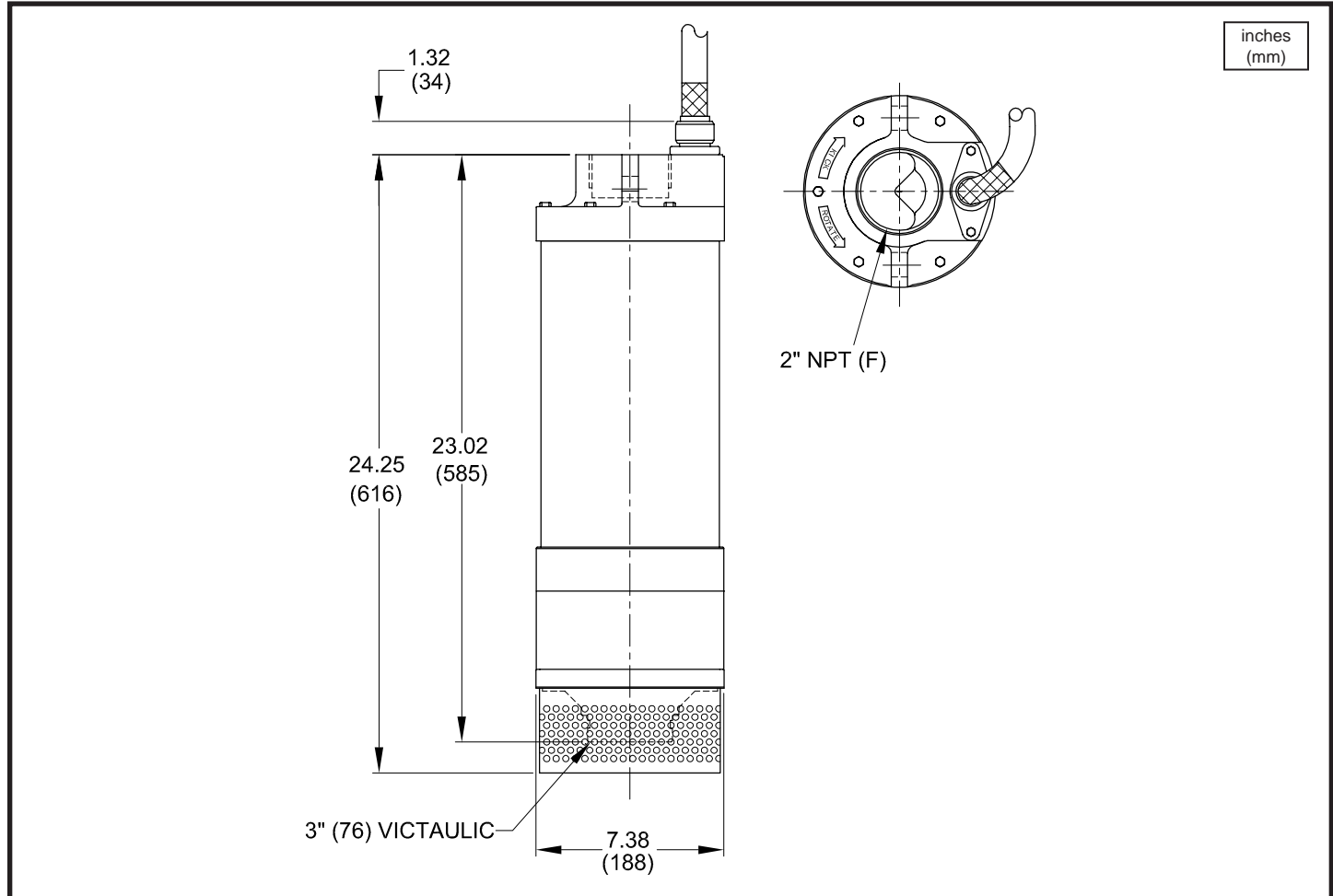

| PART NO. | HP | VOLT/PH | Hz | RPM (Nom.) | NEMA START CODE | FULL LOAD AMPS | LOCKED ROTOR AMPS | CORD SIZE | CORD TYPE | MAX. CORD LENGTH |
|---|-----|---------|----|------------|-----------------|----------------|-------------------|-----------|-----------|------------------|
| PUMP w/RAINPROOF CONTROL | | | | | | | | | | |
| 9-55132-03 | 5.0 | 230/3 | 60 | 3450 | H | 15.2 | 87.8 | 12/4 | SOW | 245Ft./75m |
| 9-55134-03 | 5.0 | 460/3 | 60 | 3450 | H | 7.6 | 43.9 | 12/4 | SOW | 982Ft./299m |
| 9-55135-03 | 5.0 | 575/3 | 60 | 3450 | H | 6.1 | 35.1 | 12/4 | SOW | 1392Ft./424m |
| PUMP w/OPTIONAL WATERTIGHT CONTROL | | | | | | | | | | |
| 9-55132-04 | 5.0 | 230/3 | 60 | 3450 | H | 15.2 | 87.8 | 12/4 | SOW | 245Ft./75m |
| 9-55134-04 | 5.0 | 460/3 | 60 | 3450 | H | 7.6 | 43.9 | 12/4 | SOW | 982Ft./299m |
| 9-55135-03 | 5.0 | 575/3 | 60 | 3450 | H | 6.1 | 35.1 | 12/4 | SOW | 1392Ft./424m |

Pump rated for operation at $\pm 10\%$ voltage at motor.

IMPORTANT !

- 1.) PUMP MAY BE OPERATED "DRY" FOR EXTENDED PERIODS WITHOUT DAMAGE TO MOTOR AND/OR SEALS.
- 2.) THIS PUMP IS APPROPRIATE FOR THOSE APPLICATIONS SPECIFIED AS CLASS I DIVISION II HAZARDOUS LOCATIONS. THE CONTROL SUPPLIED WITH THE PUMP IS NOT APPROPRIATE FOR HAZARDOUS LOCATIONS.
- 3.) THIS PUMP IS NOT APPROPRIATE FOR THOSE APPLICATIONS SPECIFIED AS CLASS I DIVISION I HAZARDOUS LOCATIONS.
- 4.) INSTALLATIONS SUCH AS DECORATIVE FOUNTAINS OR WATER FEATURES PROVIDED FOR VISUAL ENJOYMENT MUST BE INSTALLED IN ACCORDANCE WITH THE NATIONAL ELECTRIC CODE ANSI/NFPA 70 AND/OR THE AUTHORITY HAVING JURISDICTION. THIS PUMP IS NOT INTENDED FOR USE IN SWIMMING POOLS, RECREATIONAL WATER PARKS, OR INSTALLATIONS IN WHICH HUMAN CONTACT WITH PUMPED MEDIA IS A COMMON OCCURRENCE.

SECTION A
PAGE 26
DATE 7/05

Submersible Dewatering Pumps

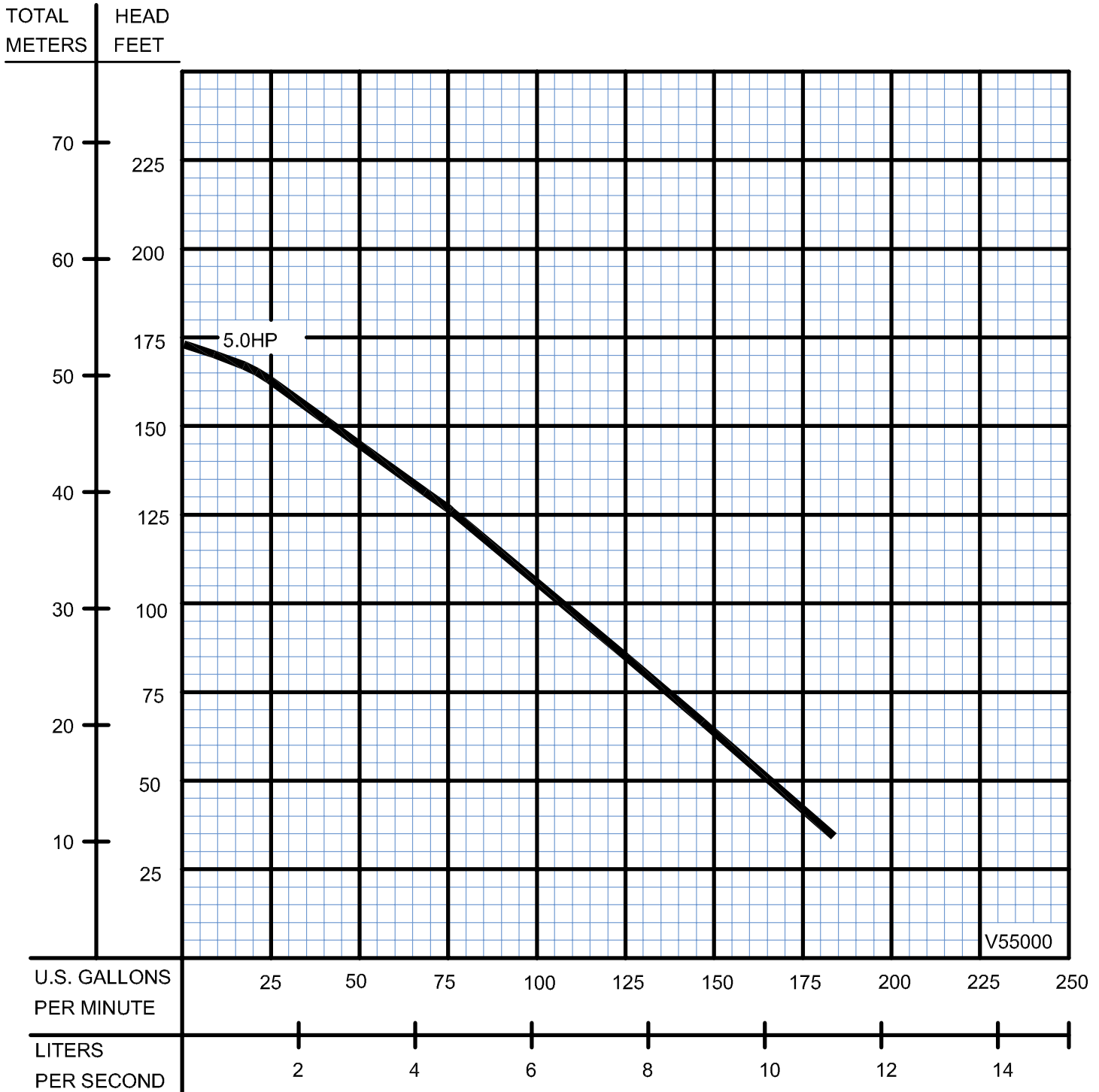

Testing is performed with water, specific gravity 1.0 @ 68° F @ (20°C), other fluids may vary performance

SECTION A
 PAGE 27
 DATE 7/05

STANDARD-LINE®

Controls for Series: 9-55000, 2 Stage
 NEMA 3R Rainproof & Optional NEMA 4 Watertight

PROSSER

Submersible Dewatering Pumps

CONTROL NEMA 3R, RAINPROOF

| | |
|------------------|--------------------|
| Pump P/N: | Control P/N |
| 9-55132-03 | 9-810834-03 |
| 9-55134-03 | 9-500834-03 |
| 9-55135-03 | 9-500835-03 |

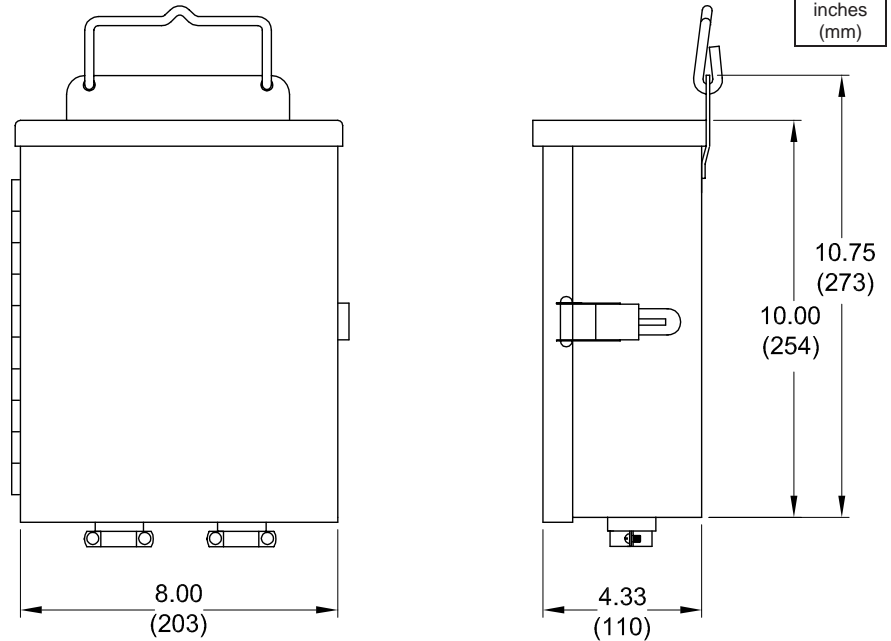

OPTIONAL - CONTROL NEMA 4, WATERTIGHT

| | |
|------------------|--------------------|
| Pump P/N: | Control P/N |
| 9-55132-04 | 9-810834-04 |
| 9-55134-04 | 9-500834-04 |
| 9-55135-04 | 9-500835-04 |

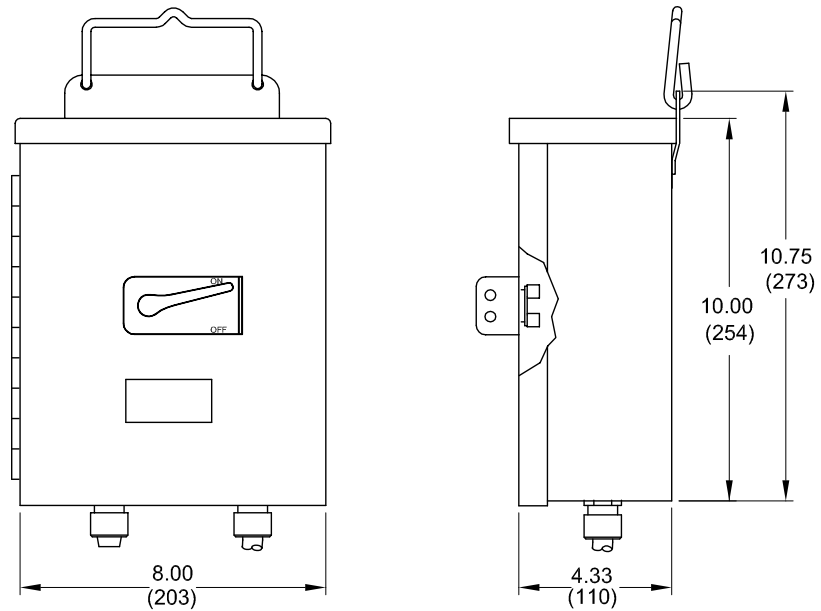

SECTION A
 PAGE 28
 DATE 7/05